

# BEST OF THE BETHS



# THE BEST OF JANUARY

# BEST OF THE BETHS



## Contents Page

1. Trump Back in Office by Jessica 12A1
2. The Picture of Dorian Gray Review by Ronnie 12H2
3. Three Cheers for Sweet Revenge Album Review by Hadi 10A
4. We Live in Time Review by Evie 12A2
5. The Autumn Budget by Martin 12E1
6. 2025 NASCAR Cup Series: Season Preview by Faeq 9B
7. Like Him or Loathe Him: Trump Back in Office by Seren 12W1
8. The Environmental Impacts of AI by Nifemi 11C
9. An Interview with Dr Viehoff by Edwin 12C1

# TRUMP BACK IN OFFICE

JESSICA 12A1

The USA and the rest of the world watched as Trump was elected on November 8, 2024. This was widely seen as a surprise upset victory. He was inaugurated as the 45th President of the United States on January 20, 2017. By the time he left office after losing the 2020 presidential election to former Vice President Joe Biden, Trump's first term was largely defined to be controversial. For example his administration faced numerous ethical concerns, including allegations of nepotism involving his family members into senior advisory roles.



The historically unusual nature of his presidency was confirmed four years later when he became the second person ever, and the first since the 19th century, elected to two non-consecutive terms. He took the oath of office for the second time on January 20, 2025.

However, despite being in the early days of his 2025 presidency, Trump is already facing significant backlash, particularly regarding his stance on the popular app TikTok. In 2020, the USA government announced that it was considering banning the Chinese social media platform TikTok upon a request from then-president Donald Trump, who viewed the app as a national security threat. On January 18, 2025, TikTok temporarily suspended its services in the United States, leaving many American users distraught with the most popular app in the world shutting down. The following day, after Trump signalled that he would grant an extension to TikTok upon being inaugurated, services were restored.



Trump's sudden switch towards restoring the app left many American citizens believing the supposed ban was a calculated, political strategy to win over the hearts of the American people. One user in the app X wrote *'The Tik Tok ban is very CLEARLY a ploy to make Trump look like a hero, as indicated by Tik Tok's statements surrounding the ban praising him for all his work to get the app back'*



This highlights how Trump's second term has already begun with significant controversy. Among his key plans are deporting undocumented migrants, and pardoning certain individuals involved in the January 6 2021 Capitol riot – when his supporters stormed the Capitol in an attempt to overturn Joe Biden's 2020 election victory.



# REVIEW: THE PICTURE OF DORIAN GRAY

RONNIE 12H3

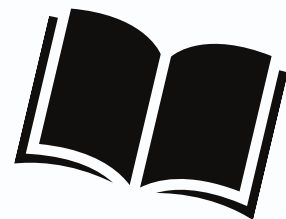

*The Picture of Dorian Gray* is a philosophical fiction novel written by Oscar Wilde in the late nineteenth century. It follows the life of the titular Dorian Gray, and his unintentional deal with the Devil (presumably) to maintain his youth for eternity. Accompanied by close friends Lord Henry Wotton and Basil Hallward, Wilde's text acts as a medium through which conceptual beauty, the passing of time, homoeroticism, and physiognomy are explored.

This book was one of many requested on my Christmas list for 2024 - I had heard very good things about it, though had never got around to reading it myself. Upon 'collecting' all of my requested books on Christmas Day, something about *The Picture of Dorian Gray*, specifically, called to me, and thus it was the first garnered novel I read. I thank myself every day for making this decision.



Whilst I enjoy nineteenth-century literature, it is not my favourite literary period; I prefer more modern and contemporary writings, particularly those that employ a 'stream-of-consciousness'. So, naively, I went into the book expecting something akin to Shelley's *Frankenstein* (which I enjoyed, though found quite tiring to read at times), yet found, to my greatest surprise, a plot and style of writing that is arguably one of the best I have ever come across.



The elegance of Wilde's prose is unparalleled - his mastery of language is exquisite, being able to employ the correct metaphors, imagery, or plot-based events right where they really *resonate*. Each and every chapter kept me more than interested, and not in the colloquial way where one may scream *wow! that got me hooked!* - no, truly engaged. The sonic flow of his words and his understanding of beauty, especially from the perspective of both the holder and admirer, surpasses anything I have read in the past, and is most likely the only competitor to Aciman's *Call Me By Your Name* that I can think of.

One of the lasting reasons why I cherish this novel is for Wilde's insertion of 'self'. His struggle with his own sexuality, his dipping into-and-out-of prose occasionally, his response to criticism and eventual censorship ergo, his self-proclaimed resonance with Basil, Henry, and Dorian in different aspects of himself, so on and so forth, all shine through when reading the work and warrant its place as, in my opinion, one of the best pieces (if not *the best*) to come of the nineteenth century. If you have not yet read *The Picture of Dorian Gray*, I urge you to do so - especially if you possess a love for English Literature, Philosophy, or Theology!

# MCR - THREE CHEERS FOR SWEET REVENGE

HADI 10A

## Album Background

Three Cheers for Sweet Revenge (2004) is the sophomore effort by American rock band My Chemical Romance. A major step up from their debut, Three Cheers is considered to be a quintessential release in the world of emo and post-hardcore, both bringing the genres into the mainstream whilst also being critically acclaimed. It topped the UK Rock and Metal charts, cracked the top 40 on the UK Mainstream Album charts and produced 3 top 40 singles. It has been certified multi-platinum worldwide.



## Track Listing

- 
1. Helena
  2. Give 'Em Hell, Kid
  3. To the End
  4. You Know What They Do...
  5. I'm Not Okay (I Promise)
  6. The Ghost of You
  7. The Jetset Life Is Gonna Kill You
  8. Interlude
  9. Thank You for the Venom
  10. Hang 'Em High
  11. It's Not a Fashion Statement...
  12. Cemetery Drive
  13. I Never Told You What I Do...



Hello there, stranger!



The band's logo, featuring the words 'MYCHEMICAL' and 'ROMANCE' in a large, black, hand-drawn, brush-stroke style font. The letters are thick and have a rough, textured appearance.

# MCR - THREE CHEERS FOR SWEET REVENGE

HADI 10A

## My Review



1. Helena - 10/10 - A punk rock track with a melodic kick. Arguably one of the least angsty songs on this album.
2. Give 'Em Hell, Kid - 8/10 - A bit more on the heavier, hardcore side. This song has quite goofy guitar bends.
3. To the End - 7/10 - I'm starting to think that this might be a concept album. That being said, the angst is yet to begin.
4. You Know What They Do to Guys Like Us in Prison - 7/10 - This song guest features The Used's Bert McCracken. I also don't know what to think about emo incarceration.
5. I'm Not Okay (I Promise) - 10/10 - This one's pretty good. According to 'sources', this is classified as an 'emo anthem'.
6. The Ghost of You - 9/10 - MCR D-Day. You'll need to watch the video for this one.
7. The Jetset Life Is Gonna Kill You - 7/10 - At this point, I've no idea what this album is about. All I know is that he's not okay.
8. Interlude - 4/10 - For me, this track kills the flow of the album. It's a bit like a bad Radiohead imitation. But his voice cracks.
9. Thank You for the Venom - 11/10 - Maybe MCR is metal(core) after all. But genuinely, this song has a crazy solo.
10. Hang 'Em High - 9/10 - Both MCR and Muse have Western-themed songs. Fun fact: MCR and Muse have supported each other during the Black Parade and Black Holes and Revelations tours - starting to see a theme here?
11. It's Not a Fashion Statement, It's a Deathwish - 9/10 - I'll admit, lots of songs on this album sound similar but they're all pretty good. Except for Interlude. Not that one.
12. Cemetery Drive - 7/10 - This song both benefits and suffers from excessive edge.
13. I Never Told You What I Do for a Living - 10/10 - If you've been attentive, it's not hard to infer what he does for a living.

*I bestow upon this album...*

**7⚡10!**



# WE LIVE IN TIME



EVIE 12A2

Almut (Florence Pugh) and Tobias (Andrew Garfield) are brought together in a surprise encounter that ultimately changes their lives. Their lives together are challenged by the limits of time as they learn to live each day like it's their last.

Their love story takes an unconventional route in John Crowley's moving romance. The decade spanning story focuses on a talented young chef and a recently divorced man who fall in love. They must come to terms with the painful circumstances of the problems that unfold during their time together.

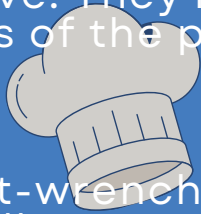

The film's heart-wrenching nature stems from its focus on the themes of illness and time. The director embraces this through his unique storytelling. Crowley intentionally chose to tell this story without chronology, the timeline lacks definition which adds to the sense of their whirlwind romance which appears to be fleeting. This is yet another A24 production that tells a story which resonates with many of its viewers. However, each story has its own complexities and intricacies which make each tale unique.



What makes the film stand out to me the most is the balance between the romance and the drama within the film. Unlike other films that bring a spotlight to the hardships of those with illnesses and those around them, this film acknowledges the couples struggles with and without the extra added pressure of time. As an audience, their chemistry is seen as funny and awkward yet charming and endearing which makes it impossible not to be consumed with their story.

As Almut comes to terms with her morality, her character's ambition and passion heightens. She juggles her roles as a mother, wife and chef, trying to be the best she can possibly be while she still can. Her chaotic energy is balanced by Tobias who has a more traditional approach to her illness and appears to be more logistical.

Overall, the film was excellent in highlighting the unpredictable nature of life in their heart-warming story full of love despite the challenges

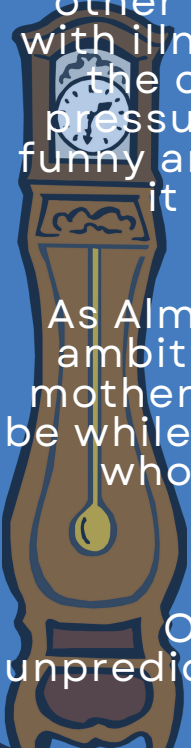

# THE AUTUMN BUDGET

MARTIN 12E1

## Background

On the 30th of October 2024, following a landslide Labour victory in the general election in the summer, Chancellor Rachel Reeves presented her Autumn budget to Parliament. This highly anticipated document certainly did not disappoint - it features massive increases to public spending, financed by unprecedented tax rises and borrowing; this budget sees the country turn away from the austerity favoured by the Conservative governments of old, and into a more interventionist economy fuelled by investment. The Chancellor has stated that the budget is “restoring to our public finances and rebuilding our public services” and restoring “economic stability”. However, this optimistic view is not shared by everyone, with many arguing that this budget is contrary to the Labour party manifesto and that it is a gamble which may lead to future tax increases, higher interest rates and higher inflation as well as recession.



## Broken Promises?

The main critique of the Autumn budget is that it fails to deliver, and even contradicts, Labour’s election promises stated in their manifesto and their stance on issues whilst in the opposition. For instance, last year Rachel Reeves stated that freezes on income tax thresholds until 2028 introduced by Sunak’s Conservative government were “picking the pockets of working people”. Despite this, a year later in the Autumn budget, it was confirmed that the existing freeze on income tax put in place by the previous government will remain as agreed until 2028. Furthermore, before the election, Labour ruled out any increases in income tax, VAT and National insurance on ‘working people, however some argue that the increase in NIC (National Insurance Contributions) by 2% in the Autumn budget opposes this. Former chancellor Jeremy Hunt has stated that raising NIC for employers leads to a “jobs tax paid for by working people” and hence “fewer jobs and less wages”. Despite these criticisms, Reeves denies breaking any election pledges, she argued in an interview that people will not see their taxes rise immediately after the budget and that national insurance will not directly affect employees, there will not be rises on VAT, national insurance or income tax.

## Opinions of Pressure Groups and Political Parties

Amongst Pressure Groups, opinions are generally fairly pessimistic. For example, the historically right-wing Adam Smith institute stated that the budget “will have the complete opposite impact to that which is intended by the Chancellor and will worsen – rather than fix – Britain's





# THE AUTUMN BUDGET

MARTIN 12E1

problems”. Contrary to this, the Institute for Government praised the new fiscal rules as measures which should support “more stable, sustainable fiscal policy”, but they did conclude that this budget’s goals will be characterised by slow, frustrating progress. When it comes to political parties, the reaction was universally negative. Former Conservative prime minister, Rishi Sunak, has stated that the chancellor has “totally failed to grip public spending”. Liberal Democrat leader, Sir Ed Davey, acknowledged that the Chancellor had to make many big decisions, but asserts that “she has got too many of them wrong”. Reform leader, Nigel Farage, has described the budget as “economically illiterate”.



## Conclusion

Overall, the political discussion in the UK paints a gloomy image of the future with this Labour budget, however it is imperative that such radical proposals and unprecedented changes will illicit panic initially, especially after the last 14 years of Conservative austerity. The only way forward is to wait and see whether these pessimistic predictions will come to pass, or whether our Chancellor was right to implement these measures.



# 2025 NASCAR CUP SERIES: SEASON PREVIEW



FAEQ 9B

Happy New Year, and welcome back to the newsletter! Hopefully, you had a restful and relaxing winter break (whether you celebrate Christmas or not) as well as time to do fun and memorable things with family and friends. I am Faeq Ojelade of 9B, and to open 2025, my focus will be a 2025 season preview for the NASCAR Cup Series. The season begins on February 2nd for the Clash at the Bowman Gray Stadium, but here are a few of the many things to look out for in 2025...

## **\*NASCAR's new media rights deal!**

It was announced in November of 2023 that NASCAR had reached new media rights agreements beginning from this year, lasting until 2031. NBC and Fox Sports remain broadcasters of the Cup Series, but joining them are TNT Sports and Amazon Prime Video. Speaking of Amazon Prime, it was announced in January that they signed a sponsorship deal with the #9 Hendrick Motorsports team and driver Chase Elliott that lasts until 2027. Prime Video will be the primary sponsor for Elliott in three races this season before broadcasting five across May and June.



The 2025 Amazon Prime Video livery for the #9 Hendrick Motorsports Chevrolet, which will be driven by Chase Elliott in 3 races. Prime Video will sponsor Elliott at Talladega (April), Kansas (May), and North Wilkesboro. This is before Prime Video will broadcast 5 consecutive NASCAR Cup Series races, beginning with the Coca-Cola 600 at Charlotte Motor Speedway.

**(IMAGE CREDIT: Hendrick Motorsports)**

## **\*NASCAR goes to Mexico City!**

Sounds interesting, but yes, it *is* happening. For the first time since 1958, the NASCAR Cup Series will race outside of the USA - meaning, Daniel Suárez (#99 Trackhouse Racing) will have a home race! Suárez is a native of Monterrey in Mexico, and the 2016 Xfinity Series Champion - he is the first foreign-born NASCAR driver to win a major National Series title. Speaking of the Xfinity Series, they shall return to Mexico City for the first time since 2008. NASCAR will race on the Autódromo Hermanos Rodríguez, a venue where other series like Formula One hold races. The track layout shall be somewhat similar to what F1 has, but with minor differences. The Cup Series race will take place on June 15th, while the Xfinity Series (NASCAR's second-tier circuit) will race on June 14th.

# 2025 NASCAR CUP SERIES: SEASON PREVIEW

FAEQ 9B



A promotional poster for the 2025 NASCAR Mexico City race weekend. The Xfinity Series race will be broadcast on The CW on June 14th, while Amazon Prime Video will broadcast the Cup Series race on June 15th.

**(IMAGE CREDIT: NASCAR)**



## **\*An in-season tournament for \$1,000,000!**

For 2025, NASCAR has introduced a bracket-style tournament that will see 32 drivers compete for \$1 million over 5 races (all of which will be broadcast on TNT Sports). The tournament begins at Atlanta on June 28th and ends at Indianapolis on July 27th (for the Brickyard 400, which is a *crown jewel* NASCAR event). The drivers will be determined in the 3 races preceding Atlanta. 32 drivers start in the first round, before it goes to 16, 8, 4 and then 2 for the final race. To advance to the next round, one driver must beat another head-to-head in the race. In the case of the final, the highest-finishing driver in the race shall win the prize money.

## **\*And of course, the championship picture!**

Last year was undoubtedly a season of enticing NASCAR action. We had close photo-finishes (including the *closest* in NASCAR Cup Series history), multiple drivers finding their way back to Victory Lane and some dramatic and chaotic races. In the end however, Joey Logano (#22 Team Penske) won his third NASCAR Cup Series Championship, preventing back-to-back titles for his teammate Ryan Blaney (#12). That's Logano's third title in the last seven seasons, and Team Penske's third on the bounce. So can they finally be defeated in the Next-Gen era?

Well... they definitely can be. Hendrick Motorsports and Joe Gibbs Racing pose the biggest threats to Penske, having each made it to the Championship 4 stage in the playoffs in most of the last six years. Kyle Larson (#5 Hendrick Motorsports) and Christopher Bell (#20 Joe Gibbs Racing) were the most dominant drivers of last season, albeit whilst finishing 6th and 5th in the points standings respectively. But, you may also want to beware of Tyler Reddick (#45 23XI Racing). Reddick emerged as a title contender in the middle of 2024, and had 3 wins at season's end. He also finished a career-high 4th in points. Those three are notable contenders, but so are a few other drivers.

# 2025 NASCAR CUP SERIES: SEASON PREVIEW



FAEQ 9B

Now, the closest I feel I can get to championship probabilities are the betting odds from DraftKings Sportsbook. Please do keep in mind that the following probability figures are *implied* (meaning they aren't literal, but rather a rough idea). Nevertheless, the favourites to win this year's NASCAR Cup Series Championship are as follows:

- T1)** Kyle Larson (#5 Hendrick Motorsports) - 15.38%
- T1)** Christopher Bell (#20 Joe Gibbs Racing) - 15.38%
- 3)** William Byron (#24 Hendrick Motorsports) - 14.29%
- 4)** Ryan Blaney (#12 Team Penske) - 13.33%
- 5)** Denny Hamlin (#11 Joe Gibbs Racing) - 11.76%
- T6)** **Joey Logano\*** (#22 Team Penske) - 10.53%
- T6)** Tyler Reddick (#45 23XI Racing) - 10.53%
- 8)** Chase Elliott (#9 Hendrick Motorsports) - 8.33%



Joey Logano (#22 Team Penske) celebrates after winning the 2024 NASCAR Cup Series Championship Race from Phoenix Raceway, and the 2024 NASCAR Cup Series Championship on November 10th 2024 in Avondale, Arizona. Logano enters the 2025 season as the defending NASCAR Cup Series Champion.

**(IMAGE CREDIT: Getty Images)**

And that's a brief preview as to what the NASCAR Cup Series brings to us in 2025! Thank you for taking time to read the article (and maybe also discover more about the world of NASCAR). If you have any questions about it, please message me privately on Teams ([@22B-Ojelade-Faeq](#)) or contact me via Microsoft Outlook. Fear not, for I am willing to listen to your feedback and respond as fast as possible. If there are any questions about the newsletter itself, please contact/go to Miss Stevens.

There is so much that can be said about this season, but that is just a glimpse. Hopefully, it proves to be another exciting year for the sport, especially given some of the things I've spoken about. Thanks again for reading, and hopefully I can give you a preview of the 2025 Formula One World Championship next month! Until then, goodbye.

**[NOTE: This article was last updated on January 24th 2025. Facts and statistics within the article are as of that date, and may be outdated with the release of the 2025 January edition.]**

# LIKE HIM OR LOATH HIM, DONALD TRUMP IS BACK IN OFFICE



SEREN 12W1



As of January 20th 2025, Donald Trump became the President of the United States of America for the second time after securing a decisive victory in the US Election in November 2024. Trump received 77,302,416 votes (49.8%), whilst Kamala Harris, his Democratic opponent, received 75,012,178 votes.

The inauguration ceremony occurs every four years on January 20th, however if this date happens to fall on a Sunday, it is moved to January 21st.

The ceremony signifies the end of one President's time in office and the start of their successors. Due to the cold weather, Trump had the ceremony moved indoors, where he and the Vice President JD Vance swore on the oath of the Bible. Vigilant viewers were quick to spot however, that Trump did not have his left hand placed on the Bible as he was sworn in. Many notable figures were in attendance. Family members to previous presidents, and former vice presidents to controversial figures, such as Elon Musk and Jeff Bezos, all witnessed him become the 47th U.S President.



His second inaugural address entailed him promising "the golden age of America begins right now." Americans were made aware of what Trump would be focusing on during his next four years as president, this including claims that he would quickly sign executive orders to halt immigration. He also pledged to pardon many of the people convicted of attacking the Capitol in January 2021.

Following the ceremony, Trump attended the Presidents Room to sign key documents, to mark what he claims to be the 'restoration of America'. So far, America has left the World Health Organisation, an end has been brought to the birthright citizenship, and we've seen the renaming of the Gulf of Mexico to the Gulf of America. Furthermore, he wishes to create a policy that recognises only two genders, and lifted the TikTok ban, despite being the person responsible for putting this forward initially. Executive orders are legally binding and are issued to the federal government without the requirement of congressional approval.

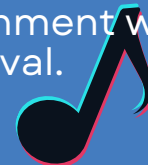

Inauguration day came to an end, as Trump made three mandatory appearances at inaugural balls. The Commander-in-Chief Ball is aimed towards military service heroes and in his speech he expressed thanks towards many branches of the U.S Armed Forces, as well as the Space Force. His supporters had the opportunity to be apart of the celebrations at the Liberty Ball. Lastly, the Starlight Ball took place, with many of the guests being major donors of the President's campaign.

# ENVIRONMENTAL IMPACTS OF AI

OLUWANIFEMI 11A

Recently, AI has experienced a significant surge in its growth and public interest. In November 2022, the release of ChatGPT marked a pivotal moment in the tech world. It reached over 100 million users within 2 months, making it the fastest growing app we've seen. As we continue to take advantage of ChatGPT and its predecessors, it's crucial for us to consider its effect on the environment and its sustainability.



When an AI model like ChatGPT receives a prompt, the prompt is divided into smaller units called tokens, whereby the AI will analyse the tokens, formulate a relevant response, and convert the tokens back to text that humans understand. A standard google search requires 0.3 Wh (watt-hours) of electricity, whereas a ChatGPT query requires 2.9 Wh, an 860% increase! Over 200 million ChatGPT queries are made daily on average, making its daily energy consumption to be roughly 621.4 MWh (megawatt-hours), which is enough to power nearly 22,000 UK homes for a day.

Besides energy, AI infrastructure relies heavily on critical minerals and rare elements such as Cobalt and Nickel for batteries, which are often mined unsustainably in countries such as Brazil and the DRC (Democratic Republic of Congo). Additionally, these facilities consume large amounts of water, as the substantial heat generated from the AI models and servers needs to be controlled to maintain optimum temperatures.

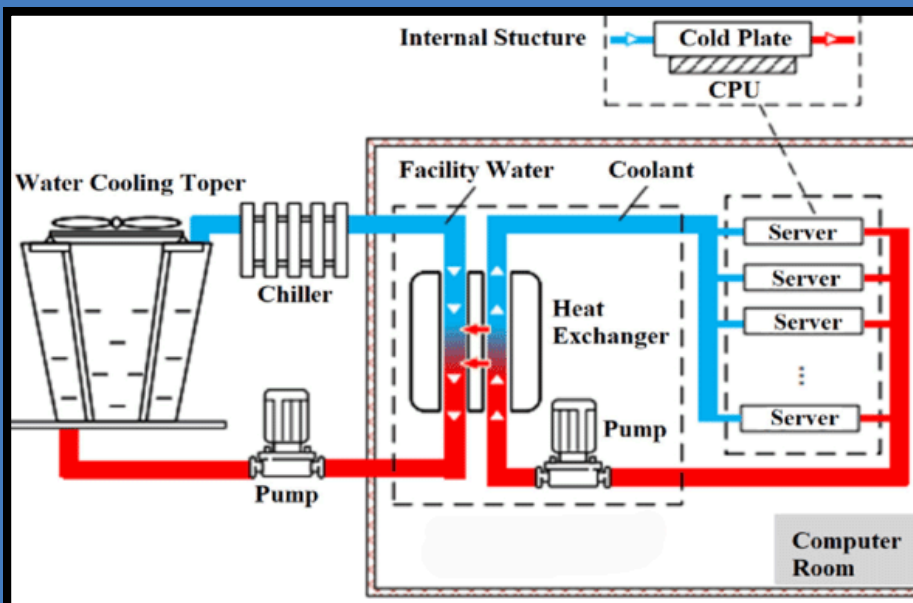

The image on the left shows a Chilled Water System, the most common cooling method in data centers. These systems use water-cooled chillers to remove heat from the air inside the data center. The chilled water circulates through cooling coils which absorb heat from the air. The heated water is then cooled again, often through evaporative cooling or cooling towers, completing the cycle.

# AN INTERVIEW WITH DR VIEHOFF

EDWIN 12C1

Not many of us will ever be able to say that we went to the Olympics and came away with a medal to prove it. Additionally, not many of us will be able to say that we managed to survive teaching Geography to a bunch of secondary school students – an arguably equally-as-difficult task. Dr Viehoff, however, is an exception – an Olympic rower, a Geography teacher, and a gardening fanatic, all in one. She was the interviewee for this month, and here's what we spoke about:

## What inspired your love for gardening?



*I do kinda believe the stuff I teach, and we teach a lot about sustainability and I felt it worked with that. And I feel like at a really competitive school like Beths, there will be students that love sports like rugby and such, but there will also always be students where those things aren't for them. I also feel like in a school like Beths, with so much land, it would be a waste not to have a gardening club. It is a work in progress – we have some plants by the entrance and in the quad, but we hope to work with DT to have a proper garden. And I think it just makes people happy to look at the plants, especially in spring.*

## Can you tell us more about your rowing career?



*I rowed in school – a grammar school in Germany – and I really enjoyed it. We rode on the Rhine, quite a big river. I just enjoyed the sport, cause its nice, its outside, you can do it in all weather. We used to do tours – we did the Loire in France and other rivers. Then someone asked me if I wanted to do it for competition. I tried it, and trained more and more and somehow ended up going to the 2000 Sydney Olympics. However, I always thought the Olympics were for other people. I just did it because I enjoyed it, and suddenly the Olympics were a possibility.*

## What is harder physically and mentally – Rowing or Teaching?

*I think I only do both of them because I enjoy them. I didn't do the rowing for the medals, and I don't do the teaching for the money. I think for both of them, you have to be quite resilient because it gets really tough. Rowing, it's really hard and tough, but you know there's an end to it in 7/8 minutes. In Teaching, you can have a really tough lesson, but the next lesson can be great. Teaching is slightly different though, as you're trying to change something in someone. Most teachers do it because they believe they can make the world a better place and make a change – I did volunteer as a rowing coach, after all.*

# AN INTERVIEW WITH DR VIEHOFF

EDWIN 12C1

## What kind of cultural significance do you believe the Olympics has?

*The Olympics like to think that it's all about participation, and not winning – when we had the 2012 Olympics in London, I think it was a great summer. However, I think in reality there's a lot of corruption and it's a little bit about the money, and who gets to host it. It's not entirely corrupt, but there is the risk that, as it is so big, people try to use it for their own interests instead of for the sake of the sport. However, despite my cynicism, I do think it's a great experience. I went to the Paris Olympics with my family – there was a great atmosphere, and I think it makes people engage in culture. And I do find them interesting from a research point – the legacies, what is left, the impact. I researched the Munich 1972 Olympics, and compared it with the London 2012 – it allowed me to combine having participated in it with my research. I was part of a conference, and together with a colleague, we wrote some chapters in a book. There's lots of geographers looking at sports, and their worldwide impact.*

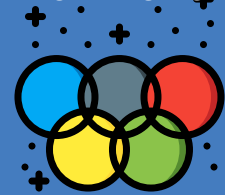

## What inspired you to become a teacher after rowing?

*I was at university, working as a researcher and lecturer after my PHD. I felt there wasn't enough engagement with students so I thought I would try it out. Both of my parents were teachers at some point – I never wanted to be a teacher in the past though. I thought you got no recognition for the hard work you do. Then I tried it... and really liked it. I did teacher training at the Institute of Education at UCL, with a scholarship from the Royal Geography Society, as there was a high demand for geography teachers, and I tried out teaching. I then swapped from universities to schools. I did find it really hard, but I did enjoy it too. Maybe that's the rower in me. If it's really hard work, then it's good, because then you must be making progress.*



And that concludes my interview for the 2025 January Edition, with Dr Viehoff! I'd like to say thank you to Dr Viehoff for giving me the chance to interview her. It is absolutely incredible how someone can find themselves journeying even to the Olympics, and still find their way to a pathway in education. I hope we can all be inspired by Dr Viehoff's passion and hard work in both rowing and teaching, and apply it to our own work as we progress further into 2025. Thank you all for reading!



# BEST OF THE BETHS



## A Note of Thanks

Thank you for reading this edition of the newsletter!

To usher in the new year, the January Edition explores politics from around the globe, and the ramifications they'll have on the world, as well as reviews of film, literature and music, all in one jam-packed edition. From sport to AI, our new year newsletter has it all.

Happy New Year, and we hope to see you once again in our February Edition!

-Regards from the Best of the Beths Newsletter team.